

HD 21 B

LHU 8

Courbes de charges - Lastkurven - Load diagrams - Curvas de cargas - Curve di carico

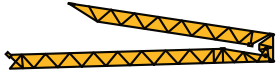

① 2000 kg

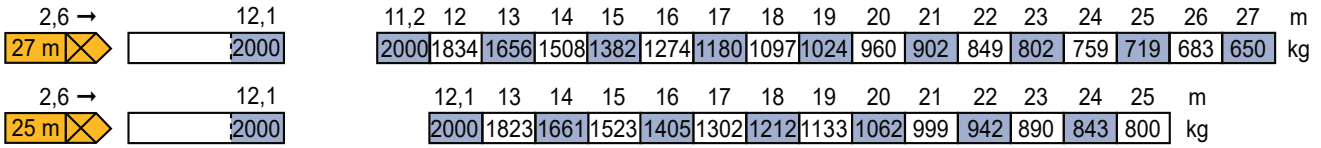

② 1500 kg

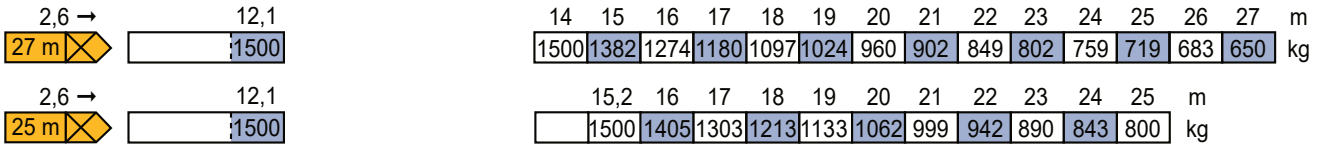

Flèche relevée - Ausleger in Steilstellung - Luffing jib - Flecha izada - Braccio impennato

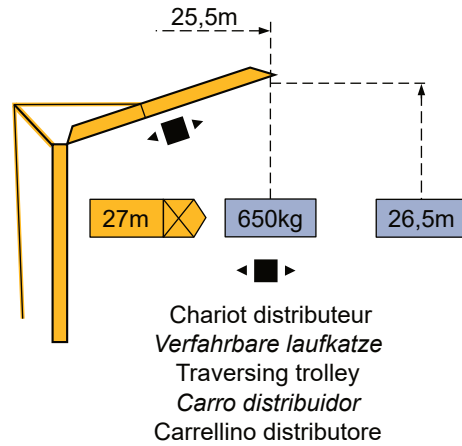
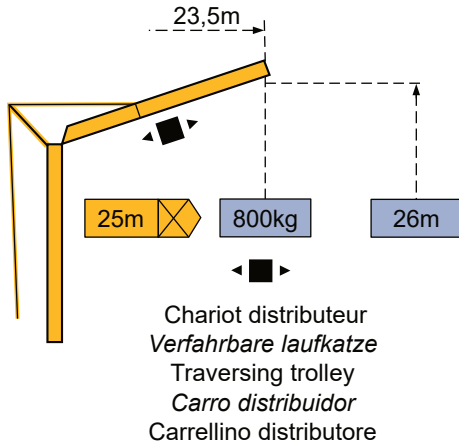

Réaction - Eckdrücke - Reactions - Reacciones - Reazioni

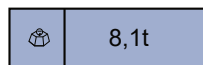
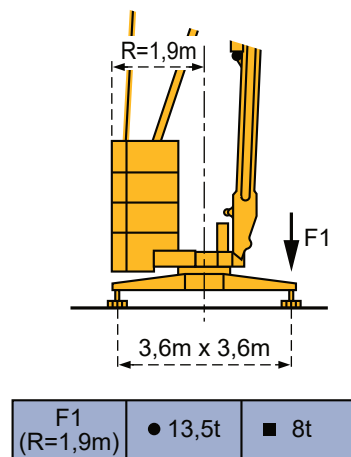
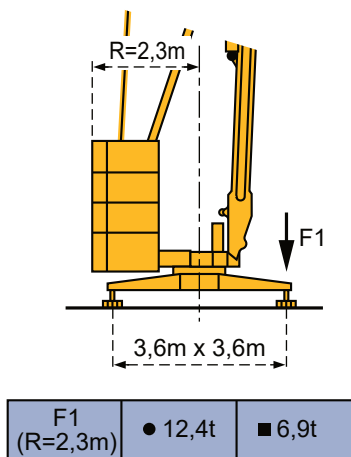

● En service
■ Hors service

● In Betrieb
■ Ausser Betrieb

● In service
■ Out of service

● En servicio
■ Fuera de servicio

● In servizio
■ Fuori servizio

⊕ A vide sans lest ni train de transport avec flèche et hauteur maximum.

⊕ Ohne Last, Ballast und Transportachse, mit Maximalausleger und Maximalhöhe.

⊕ Without load, ballast or transport axles, with maximum jib and maximum height.

⊕ Sin carga, sin lastre, ni tren de transporte, flecha y altura máxima.

⊕ A vuoto, senza zavorra ne assali di trasporto con braccio massimo e altezza massima.

Mécanismes - Antriebe - Mechanisms - Mecanismos - Meccanismi

				m/min	Kg	ch -PS hp	kW
Levage Heben Hoisting Elevación Sollevamento	① ▲ ● ▼ 2000kg	9 PC 10		6,6	2000	8,2	6
				20	2000		
				40	1000		
	② ▲ ● ▼ 1500kg	6 PC 7		9,5	1500	6	4,4
				19	1500		
				38	750		
Distribution - <i>Katzfahren</i> - Trolleying <i>Distribución</i> - Distribuzione		2 D2 V4	18 - 36		2	1,5	
Orientation - <i>Schwenken</i> - Slewing <i>Orientación</i> - Rotazione		RVF 30	0 → 0,9 tr/min - U/min - rpm		1,5	1,1	
Réseau - <i>Netzstrom</i> - Mains supply - <i>Red</i> - Rete elettrica					CEI 38 IEC 38	400V(+6%-10%) 50 Hz	
Puissance électrique nécessaire - <i>Anschlusswert</i> - Necessary electric power <i>Potencia eléctrica necesaria</i> - Potenza elettrica necessaria					① = 12 kVA ② = 10 kVA		
Groupe électrogène - <i>Stromaggregat</i> - Generator set - <i>Grupo electrogeno</i> - Gruppo elettrogeno					*		

*Nous consulter - *Auf Anfrage* - Consult us - *Consultarnos* - Consultateci

Conforme aux directives CEE 84/534 et 87/405 sur le niveau acoustique - *Gemäss EWG-Richtlinien 84/534 und 87/405 für den Schall- Leistungspegel*
 In compliance with the EEC 84/534 and 87/405 Instructions on noise level - *Conforme con las directivas CEE 84/534 y 87/405 sobre el nivel acustico*
 Conforme alle direttive CEE 84/534 e 87/405 sul livello acustico

Montage - Montage - Erection - Montaje - Montaggio

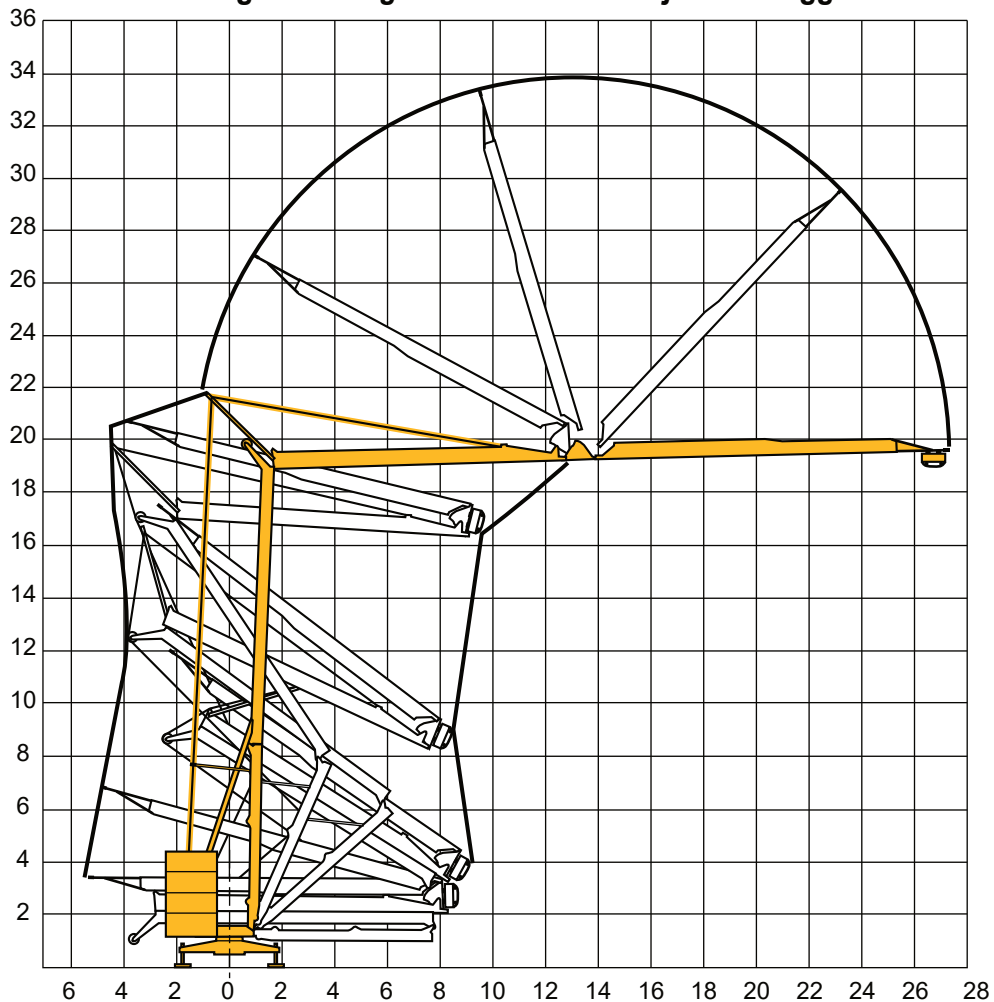

Transport - Transport - Transport - Transporte - Trasporto

18/27
15A/25A

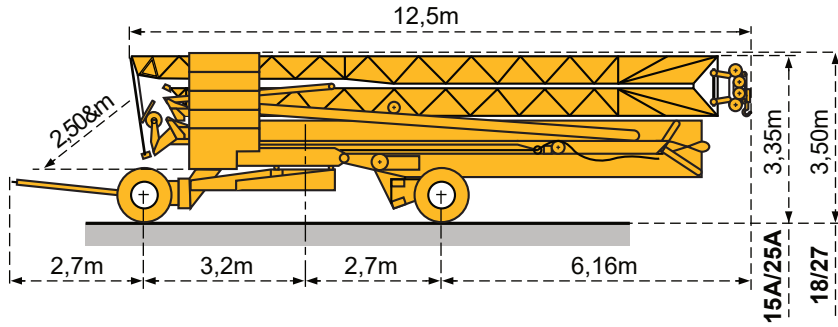

DJ125/S105
DS60/S105
DS60/S80 ●
DS51/S70 ●

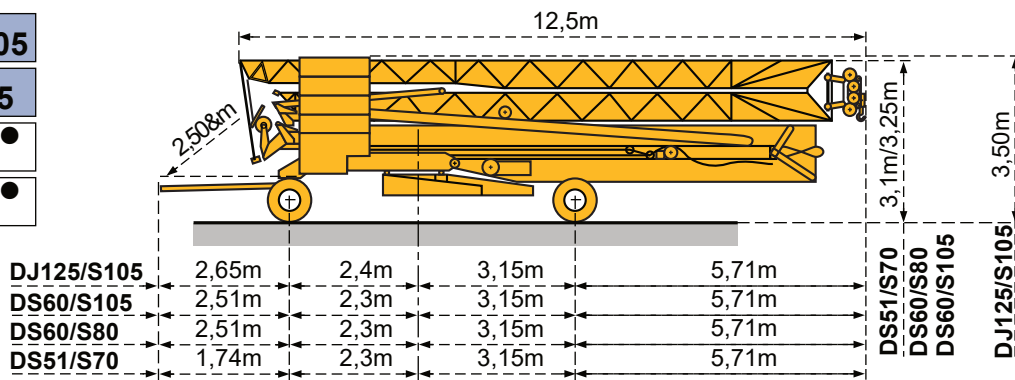

● Chantier
Baustelle
Site
Obra
Cantiere



NF E 52081 - 82
DIN 15018.H1 B3



18.Rue de Charbonnières, B.P. 173-F 69132 ECULLY Cedex
Tél. (33)04.72.20.20.20 - Fax (33)04.72.20.20.00
http://www.potain.fr - E-mail : mkt@potain.fr

POTAIN GmbH Deutschland Tel : 06.105.704.0
SIMMAPOTAIN Italia Tel : 039.65.631
Zhangjiagang POTAIN China Tel : 520. 877.1451

Copyright.Reproduction interdite © POTAIN 1994



HD 21 B

Réf. 1994.27 LHU 8