

# HD 16 B

LII 6

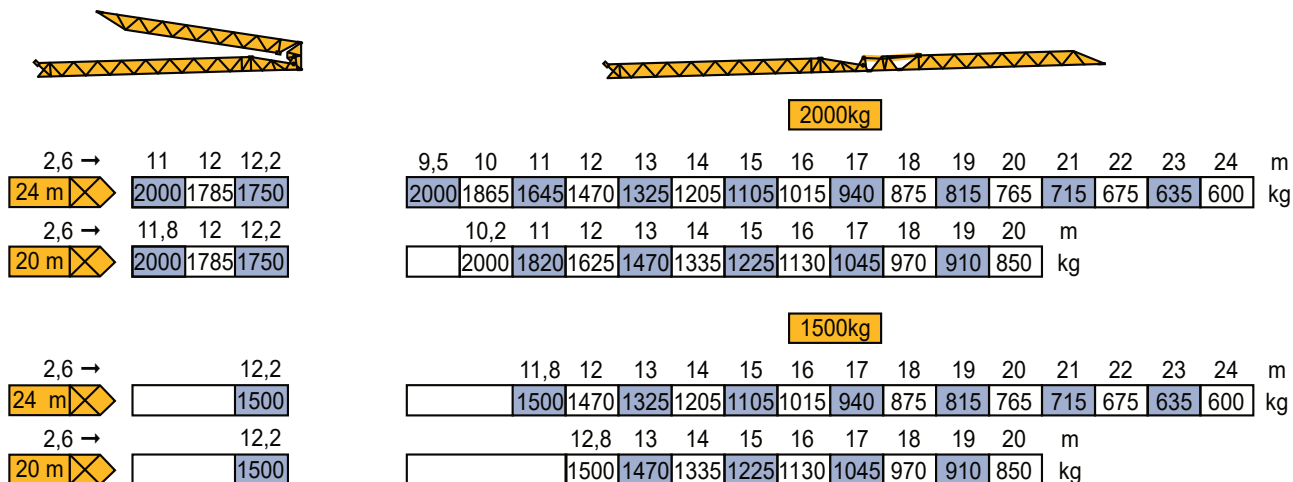

**Courbes de charges - Lastkurven - Load diagrams - Curvas de cargas - Curve di carico**



**Flèche relevée - Ausleger in Steilstellung - Luffing jib - Flecha izada - Braccio impennato**

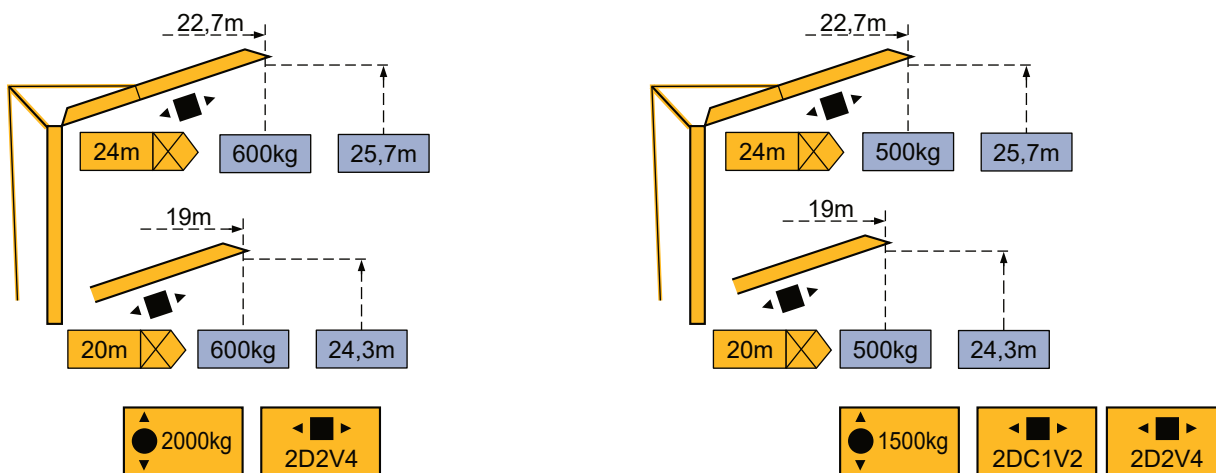

◀ ■ ▶ Chariot distributeur Verfahrbare laufkatze Traversing trolley Carro distribuidor Carrellino distributore

**Réaction - Eckdrücke - Reactions - Reacciones - Reazioni**

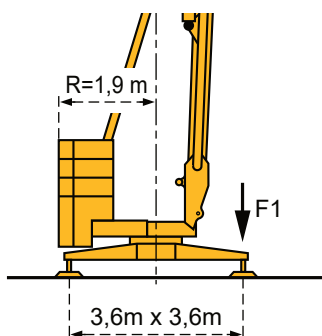

F1	● 11,95t	■ 7,4t
⊕	7,6t	

● En service  
■ Hors service

● In Betrieb  
■ Ausser Betrieb

● In service  
■ Out of service

● En servicio  
■ Fuera de servicio

● In servizio  
■ Fuori servizio

⊕ A vide sans lest ni train de transport avec flèche et hauteur maximum.











⊕ Ohne Last, Ballast und Transportachse, mit Maximalausleger und Maximalhöhe.

⊕ Without load, ballast or transport axles, with maximum jib and maximum height.

⊕ Sin carga, sin lastre, ni tren de transporte, flecha y altura máxima.

⊕ A vuoto, senza zavorra ne assali di trasporto con braccio massimo e altezza massima.

## Mécanismes - Antriebe - Mechanisms - Mecanismos - Meccanismi

				m/min	kg	ch -PS hp	kW
Levage Heben Hoisting Elevación Sollevamento	 2000kg	9 PC 10		6,6	2000	8,2	6
				20	2000		
				40	1000		
	 1500kg	6 PC 7		9,5	1500	6	4,4
				19	1500		
				38	750		
Distribution - <i>Katzfahren</i> - Trolleying Distribución - Distribuzione		2 D2 V4	18 - 36	2000/1500	2	1,5	
		2 DC1 V2	30	1500	2	1,5	
Orientation - <i>Schwenken</i> - Slewing Orientación - Rotazione		RVF 30	0 → 1 tr/min - U/min - rpm	1,5	1,1		
Réseau - <i>Netzstrom</i> - Mains supply - <i>Red</i> - Rete elettrica					CEI 38 IEC 38	400V(+6%-10%) 50 Hz	
Puissance électrique nécessaire - <i>Anschlusswert</i> - Necessary electric power <i>Potencia eléctrica necesaria</i> - Potenza elettrica necessaria					9PC : 12 kVA 6PC : 10 kVA		
Groupe électrogène - <i>Stromaggregat</i> - Generator set - <i>Grupo electrogeno</i> - Gruppo elettrogeno					*		

\*Nous consulter - *Auf Anfrage* - Consult us - *Consultarnos* - Consultateci

Conforme aux directives CEE 84/534 et 87/405 sur le niveau acoustique - *Gemäss EWG-Richtlinien 84/534 und 87/405 für den Schall- Leistungspegel*  
 In compliance with the EEC 84/534 and 87/405 Instructions on noise level - *Conforme con las directivas CEE 84/534 y 87/405 sobre el nivel acustico*  
 Conforme alle direttive CEE 84/534 e 87/405 sul livello acustico

## Montage - Montage - Erection - Montaje - Montaggio

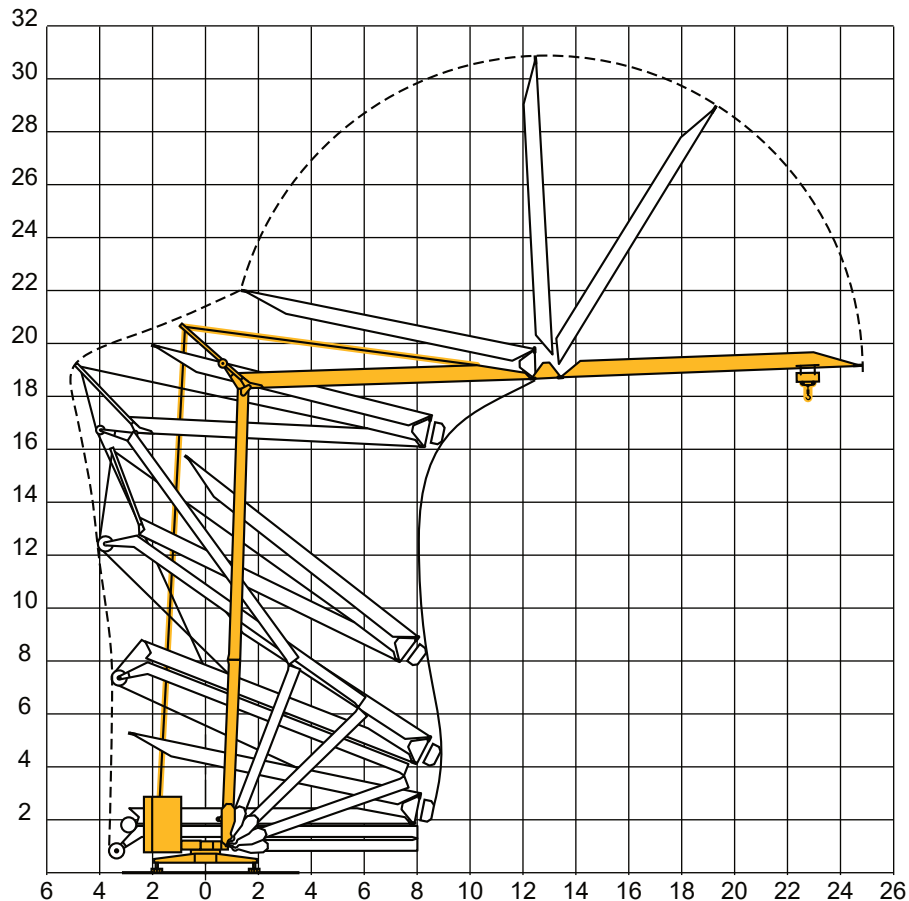

# Transport - Transport - Transport - Transporte - Trasporto

- 18/27
- 15A/25A
- 14A/21A

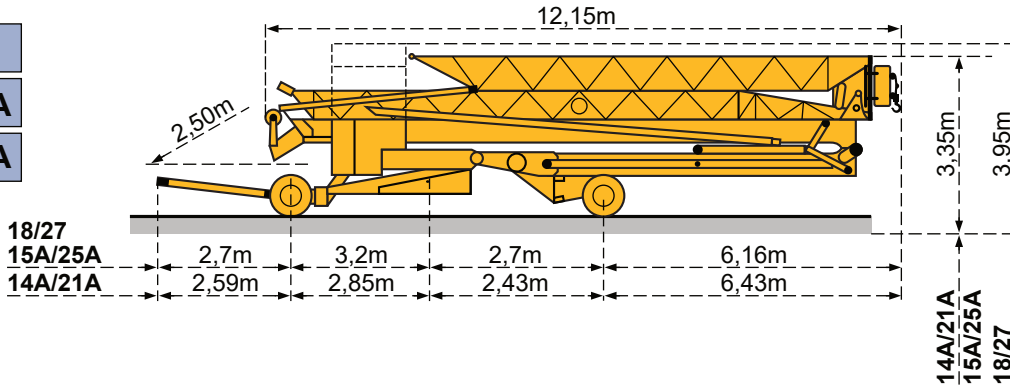

- DJ125/S105
- DS95/S105
- DS60/S105
- DS60/S80°
- DS51/S70°

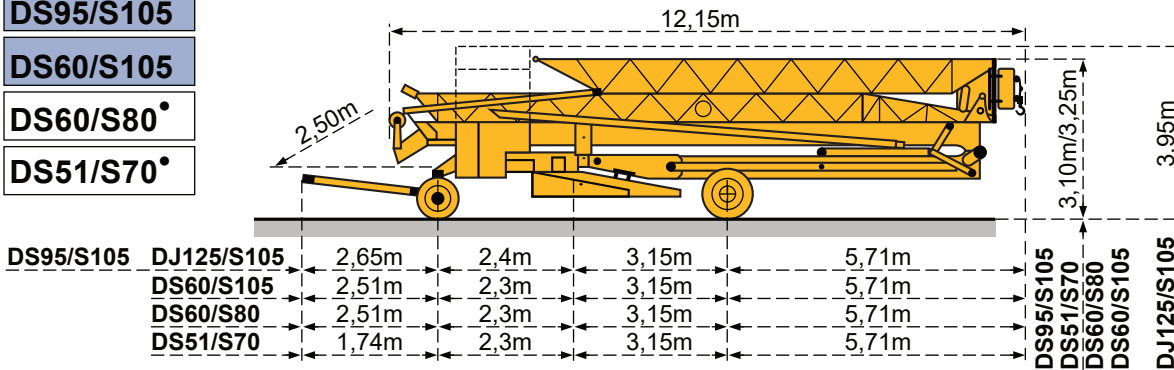

- Chantier
- Baustelle
- Site
- Obra
- Cantiere



NF E 52081 - 82  
DIN 15018.H1 B3



Copyright.Reproduction interdite © POTAIN 1995

**POTAIN** TP

GRUPE LEGRIS INDUSTRIES

18.Rue de Charbonnières, B.P. 173-F 69132 ECULLY Cedex  
Tél. (33)04.72.20.20.20 - Fax (33)04.72.20.20.00  
<http://www.potain.fr> - E-mail : [mkt@potain.fr](mailto:mkt@potain.fr)

POTAIN GmbH Deutschland Tel : 06.105.704.0  
SIMMAPOTAIN Italia Tel : 039.65.631  
Zhangjiagang POTAIN China Tel : 520. 877.1451

**WILLOH** Kranservice

HD 16 B

Ref. 1995.04. LII 6